



SPE-LV6 Automated Workstation

Compact solid phase extraction system.
Make your sample preparation process
more reliable and secure.

Innovative technology for all applications.

Technology	Positive pressure technology
Number of position	6 positions
Mix column sizes/run	Yes - individual position control
Column sizes compatible	1 mL / 3 mL / 6 mL SPE columns ; FPLC columns 1 mL
Sample volume range	From 0.1 mL to 5L
Sample injection	Volume from 0.1 mL to 25 mL - Autosampler with sample loop Volume from 10 mL to 5L – Syringe pump RSD < 1 - High reproducibility & accuracy
Sample tubes	13x100 (with /out caps) & 18x150 mm test tubes with autosampler
Solvents	Up to 10 solvents (with autosampler sample injection - integrated) Up to 4 solvents (with syringe pump injection - integrated)
Flow rate	From 50 µL to 15 mL/min
Automatic rinsing	Yes - no cross contamination
Inert material	Yes
Calibrated fluidic tubings	Yes - dead volumes controlled
Collection tube sizes	12x32 mm vials (up to 5 collections per position) 12x75 mm test tubes (up to 5 collections per position) 13x100 mm test tubes (up to 5 collections per position) 16x100 mm test tubes (up to 4 collections per position) 18x150 mm test tubes (up to 4 collections per position) 28x140 mm test tubes (up to 2 collections per position)

Waste Treatment	Automatic separation of organic/halogenated/aqueous wastes
Gas supply	Max 2.5 bar (29psi) - Consumption : 0.12LPM during drying column step Nitrogen or air compressed
Integrated software	Yes - offline version available
Touch Screen	9" - 2GB memory
Data report	Automatic recording - txt file
Export data/method	USB 2.0
Temperature	5 to 40°C
Humidity	0 to 93% (non-condensing)
Max sound level	<55db
Power	150W
Power supply	100-240 VAC (+/- 10%); 50-60 Hz
Electrical protection	2 x Delayed action fuse 1.25 A T H250V (5x20mm)

Dimensions & Weight

Weight : 25 kg

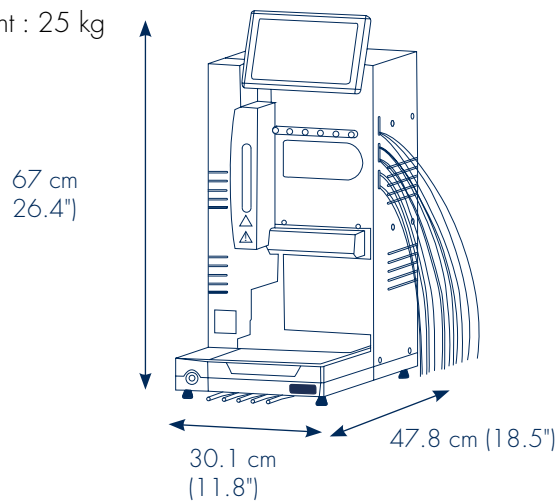

Certification	CE, CSA certified (CB certificate available on request)
----------------------	---

